

LJN-()-()

Flush Mounted Underwater Junction Box

Construction: Cast bronze with stainless steel fasteners.

Grounding: Internal grounding lug for each fixture.

Gasket: Flat black neoprene rubber.

Cord Seals: Machined brass, compression type for 16-3 Type STOW submersible cable, and AWG No. 8 copper bonding wire, factory installed with PVC male adapters.

Safety: Underwriters Laboratories Listed for underwater and dry applications.



Model Number	Power		Lighting	
	Qty	Size	Qty	Size
LJN-1(*)†	1	3/4"	1 to 4	3/4"
LJN-2(*)†	2	3/4"	1 to 4	3/4"

* Specify required number of lighting connections.

† Specify (S) for side connections and (B) for bottom connections.

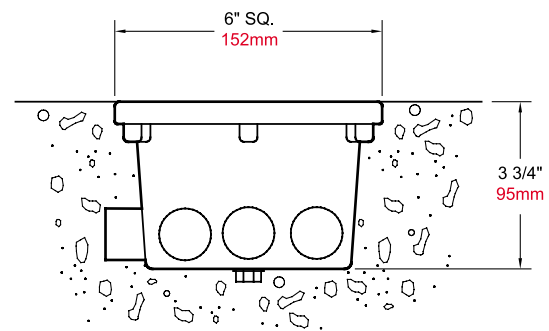

Speaking the language of water.™

