

## FDR-400-BR

### Brass Area Drain

- Designed to enhance Fountain in a Can™ installations.
- Precision machined brass grate finished to match Fountain in a Can™ top.
- Grate is ADA compliant.
- Deep Drawn stainless steel sump with ground screw and stainless steel fasteners.
- 4" FPT connection (specify side or bottom).

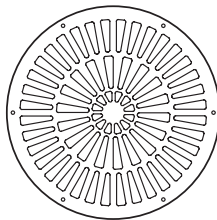

## FDR-400-SS

### Stainless Steel Area Drain

- Designed to enhance Fountain in a Can™ installations.
- Stainless steel grate finished to match Fountain in a Can™ top.
- Grate is ADA compliant.
- Deep Drawn stainless steel sump with ground screw and stainless steel fasteners.
- 4" FPT connection (specify side or bottom).

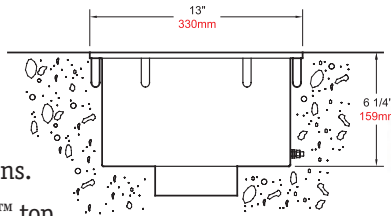

## R-50

### Mechanical Float Valve with Niche

- Brass valve with a plastic float.
- 3/4" threaded connection.
- Valve allows for minor adjustment in water level.
- Niche and face plate are white acrylic.
- For optional brass face plate, add suffix **-B** to catalog number.
- Maximum flow rate is 15 GPM; **57 LPM**.

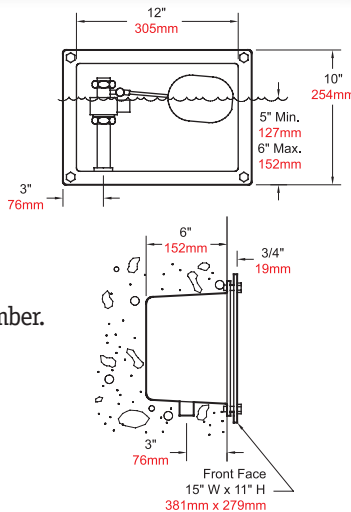

## R-50/R-51



## R-51

### Mechanical Float Valve

- Brass valve with a plastic float.
- 1/2" threaded connection.
- Valve allows for minor adjustment in water level.
- Maximum flow rate is 15 GPM; **57 LPM**.

